

DAx12000 - 1CH, 2.5 GS/sec, 12-Bit, Arbitrary Waveform Generator (USB interface)

Made by WavePond® - A division of Chase Scientific Company

Last Updated 2019-12-11

FEATURES

- (1) Chan, 2.5 GS/sec/chan, 12-Bit D/A resolution
- DC Coupled into 50 ohms; 2, 8 MSamples/Ch
- 1ppm Internal Clock Stability, < 5psec Jitter
- SFDR less than -50 dbc @ 825 MHz (min)
- Full scale Trise/Tfall = 180 picoseconds (typ)
- Internal Master Clock, Int./Ext. Trigger
- Programmable segmentation size, trig, looping, etc.
- (2) TTL marker outputs
- Aluminum USB Enclosure
- Software GUI and API for Windows XP, 7, and 10. Email for others.



APPLICATIONS

- Radar Signal Generation and Testing
- Telecom / Data Communications
- Optical and Magnetic Storage Testing
- Arbitrary RF Signal Generation
- Wireless Communications Testing
- Real World Simulations
- Network Analysis
- Pulse Generation

DESCRIPTION

General

The 1 channel, 2.5 GSPS, DAx12000 is a highly versatile PC controlled Arbitrary Waveform Generator. It incorporates many advanced features such as programmable segment sizes, looping, and individual segment triggering. Since the data downloaded to the card can be arbitrary almost any waveform that the user can imagine can be created. Whether it be random noise, a custom shaped pulse, a pure sine wave, a modulated subcarrier, or an encoded radar signature, the DAx12000 will faithfully reproduce it.

The high speed D/A converter (DAC) can be clocked internally or externally (opt.). Because the DAC is only running at half of its maximum clock rate of 5.0 GHz, the signal quality is exceptional. Most products in the AWG market are usually running at their maximum clock rates at reduced quality to meet marketing goals.

Triggering

The DAx12000 board can be triggered by a TTL signal, pulsed PECL, or software command. Looping can be set for continuous or under user program control.

Memory

The DAx12000 comes standard with 2 Mega-Samples (8MS optional) of independent memory PER channel. Segment size controls are common to both channels.

GUI Interface and SDK

The DAx12000 comes with a GUI program that can perform tasks like loading waveforms from a file to generating sine / square / and triangle waves, changing clock rates, triggering etc. The user programming interface for the DAx12000 is a simple DLL that uses C type software calls that are compatible with most software development tools.

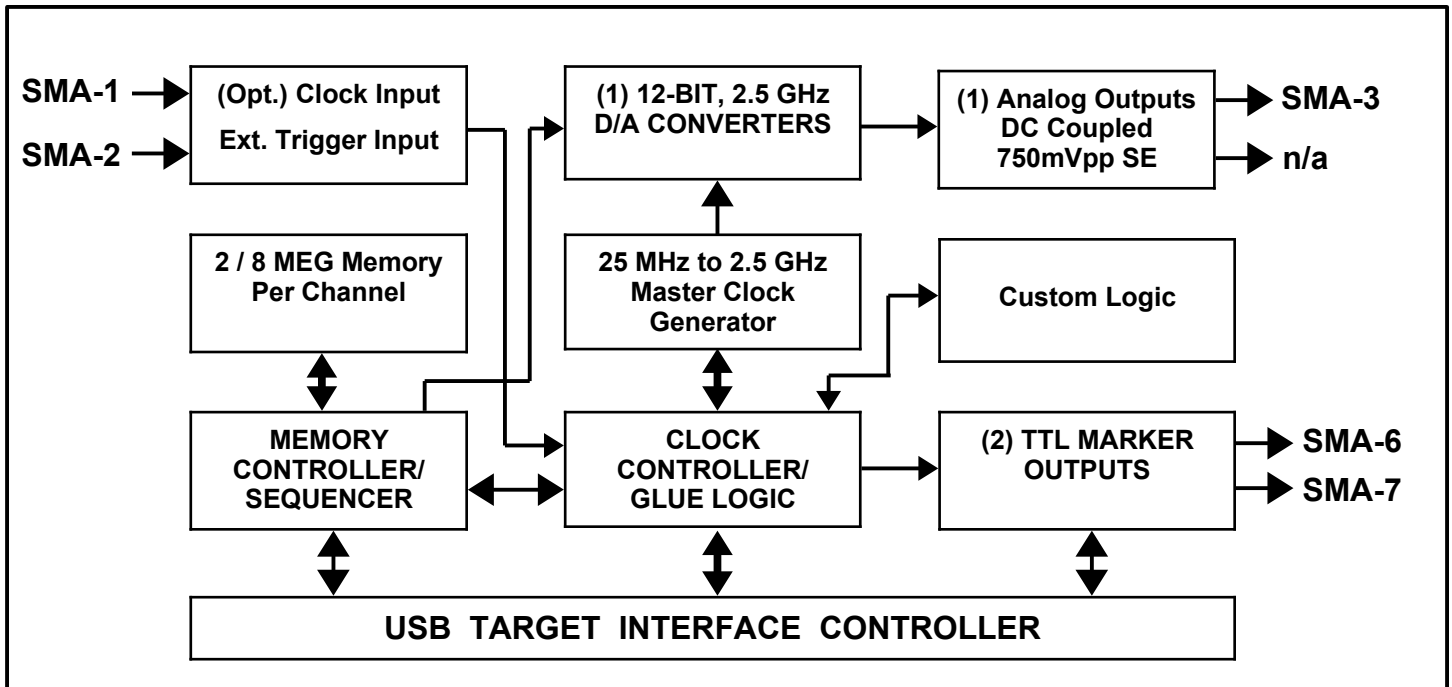

DAx12000 BLOCK DIAGRAM

SPECIFICATIONS

Analog Output: (Single Channel)
(T=25°C unless otherwise stated)

Parameter	Conditions/other	Typical Values
Vertical Resolution	Fclk = 2.5 GHz	12-Bit (1 out of 4096)
Output Impedance/Coupling		50 ohms / DC Coupling
Amplitude		
(1) Fixed outputs	Fclk = 2.5GHz	750 mVpp typical single-ended into 50 ohms (SMA connectors)
Rise Time (20-80%, no filters)		180 psec typical into 50 ohms
Fall Time (20-80%, no filters)		180 psec typical into 50 ohms
Internal Clock Jitter		< 5 psec typical
Delay between trigger and output		36 ns typical @ 2GHz
Maximum re-trigger rate		2 MHz
SFDR (Spurious Free Dynamic Range)		
DC < Fout < 825 MHz, Fclk = 2.50 GHz < -50 dB Minimum		
Internal Clock Rate Generator		
Frequency range		25 MHz to 2.5 GHz
Resolution		< 10 KHz (typ.)
Stability	T = 0°C – 70°C	+/- 1 ppm
Memory		
Waveform	Base Model	2 MWords x 12-Bits
	Maximum RAM	8 MWords x 12-Bits
# of User Segments		1 to 60 segments (max)
Segment Size Range		48 Samples up to total memory
Segment Resolution		16 Samples
Maximum Segment Loops		65,534
DIGITAL OUTPUTS:		
(2) TTL Markers	Fclk/16 resolution, 50 ohms output impedance, 3.3VTTL	
DIGITAL INPUTS:		
Ext. Clk Input	(custom Option) 50 ohms SMA inputs: 100 MHz to 2.0 GHz, square Wave, 0dBm-10dBm, AC coupled.	

TTL Trigger Input Rising Edge Retriggerable SMA connector, DC coupled, Threshold=1.0V, 50 ohms.

ENVIRONMENTAL (DAx12000)

Temperature
Operating 15°C to 30°C Ambient
Non-operating -40°C to 85°C

Humidity
Operating 20% to 80% (no condensation)
Nonoperating 5% to 95% (no condensation)

Power
+5V TBD Watts @ 2MWords Typical Not Active
 TBD Watts @ 2 MWords Typical Active

Size
DA22000-Box L=4.75", W=4.75", H=1.5"

ORDER INFORMATION

Model Number	Description
DAx12000-2M	1-Ch, 2.5 GSPS w / 2 MEG Memory/Ch
DAx12000-8M	1-Ch, 2.5 GSPS w / 8 MEG Memory/Ch

The information herein is subject to change without notice from WavePond®. All marks and product names are property of their respective owners.